



TOA

PA AMPLIFIERS

OPERATING INSTRUCTIONS

A-2030 L	A-2030 H
A-2060 L	A-2060 H
A-2120 L	A-2120 H
A-2240 L	A-2240 H

Please follow the instructions in this manual to obtain the optimum results from this unit.
We also recommend that you keep this manual handy for future reference.

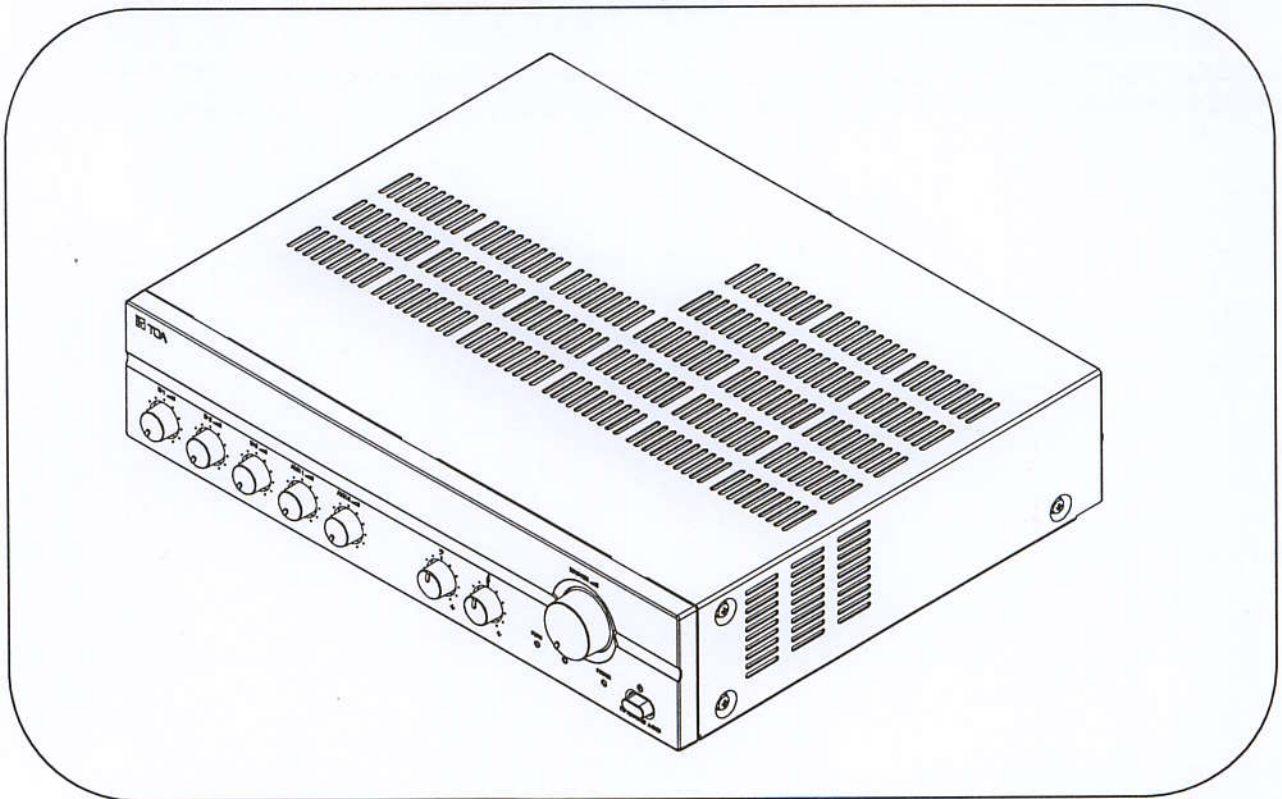

Table of contents

1. SAFETY PRECAUTIONS	2	7. CONNECTIONS	
2. GENERAL DESCRIPTION	3	7.1. Input Connection	5
3. FEATURES	3	7.2. Output Connections	6
4. NOMENCLATURE AND FUNCTIONS		7.3. Example of External Equipment	
4.1. Front	3	Connections.....	6
4.2. Rear	3	8. VOLUME CONTROL SETTINGS	7
5. MUTING FUNCTIONS	4	9. BLOCK/LEVEL DIAGRAM.....	7
6. INSTALLATION	5	10. DIMENSIONAL DIAGRAM.....	7
		11. SPECIFICATIONS	8

TOA Corporation

1. SAFETY PRECAUTIONS

- Be sure to read the instructions in this section carefully before use.
- Make sure to observe the instructions in this manual as the conventions of safety symbols and messages regarded as very important precautions are included.
- We also recommend you keep this instruction manual handy for future reference.

Safety Symbol and Message Conventions

Safety symbols and messages described below are used in this manual to prevent bodily injury and property damage which could result from mishandling. Before operating your product, read this manual first so you are thoroughly aware of the potential safety hazards as well as understand the safety symbols and messages.

WARNING

Indicates a potentially hazardous situation which, if mishandled, could result in death or serious personal injury.

CAUTION

Indicates a potentially hazardous situation which, if mishandled, could result in moderate or minor personal injury, and/or property damage.

WARNING

When Installing the Unit

- Do not expose the unit to rain or an environment where it may be splashed by water or other liquids, as doing so may result in fire or electric shock.
- Use the unit only with the voltage specified on the unit. Using a voltage higher than that which is specified may result in fire or electric shock.
- Do not cut, kink, otherwise damage nor modify the power supply cord. In addition, avoid using the power cord in close proximity to heaters, and never place heavy objects --including the unit itself -- on the power cord, as doing so may result in fire or electric shock.
- The terminals marked with the symbol  are hazardous live. The external wiring to these terminals requires installation by an instructed person.
- The socket-outlet shall be installed near the equipment and the plug (disconnecting device) shall be easily accessible.
- Be sure to replace the unit's terminal cover after connection completion. Because the voltage of up to 100V is applied to the high impedance speaker terminals, never touch these terminals to avoid electric shock.
- Be sure to ground to the safety ground (earth) terminal to avoid electric shock. Never ground to a gas pipe as a catastrophic disaster may result.

When the Unit is in Use

- Should the following irregularity be found during use, immediately switch off the power, disconnect the power supply plug from the AC outlet and contact your nearest TOA dealer. Make no further attempt to operate the unit in this condition as this may cause fire or electric shock.
 - If you detect smoke or a strange smell coming from the unit.
 - If water or any metallic object gets into the unit.
 - If the unit falls, or the unit case breaks.
 - If the power supply cord is damaged (exposure of the core, disconnection, etc.)
 - If it is malfunctioning (no tone sounds.)
- To prevent a fire or electric shock, never open nor remove the unit case as there are high voltage components inside the unit. Refer all servicing to your nearest TOA dealer.
- Do not place cups, bowls, or other containers of liquid or metallic objects on top of the unit. If they accidentally spill into the unit, this may cause a fire or electric shock.
- Do not insert nor drop metallic object or flammable materials in the ventilation slots of the unit's cover, as this may result in fire or electric shock.

CAUTION

When Installing the Unit

- Never plug in nor remove the power supply plug with wet hands, as doing so may cause electric shock.
- When unplugging the power supply cord, be sure to grasp the power supply plug, never pull on the cord itself. Operating the unit with a damaged power supply cord may cause a fire or electric shock.
- When moving the unit, be sure to remove its power supply cord from the wall outlet. Moving the unit with the power cord connected to the outlet may cause damage to the power cord, resulting in fire or electric shock. When removing the power cord, be sure to hold its plug to pull.
- Do not block the upper panel ventilation slots in the unit's cover. Doing so may cause heat to build up inside the unit and result in fire.
- Avoid installing the unit in humid or dusty locations, in locations exposed to the direct sunlight, near the heaters, or in locations generating sooty smoke or steam as doing otherwise may result in fire or electric shock.

When the Unit is in Use

- Do not place heavy objects on the unit as this may cause it to fall or break which may result in personal injury and/or property damage. In addition, the object itself may fall off and cause injury and/or damage.

2. GENERAL DESCRIPTION

TOA's Basic Amplifiers A-2030, A-2060, A-2120 and A-2240 are high performance mixer power amplifiers suited for broadcasting paging or background music in schools, offices, shops, factories, mosques, churches and large rooms.

3. FEATURES

- High durability, high reliability, and high performance.
- Three microphone inputs, two AUX inputs, and one recording output.
- Speaker output of constant voltage distribution system (70V or 100V) and low impedance (4Ω).
- Operates on both AC and DC power.
- Muting function.
- Independent input volume controls and master volume control.
- Independent tone controls of boost and cut type for both high and low frequencies.
- MIC 1 with phantom power for condenser microphones.
- Current limiter circuitry protects transistors, and the thermal protection circuitry prevents a failure due to overheat.
- All MIC inputs are electronically-balanced input.

4. NOMENCLATURES AND FUNCTIONS

4.1. Front

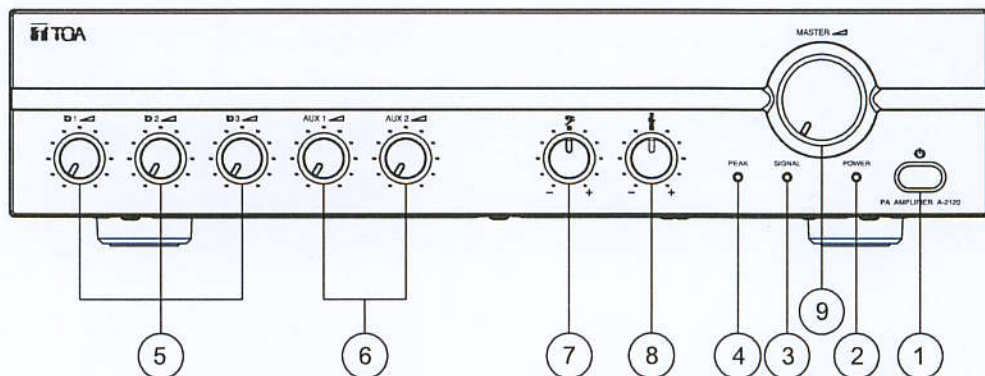

4.2. Rear

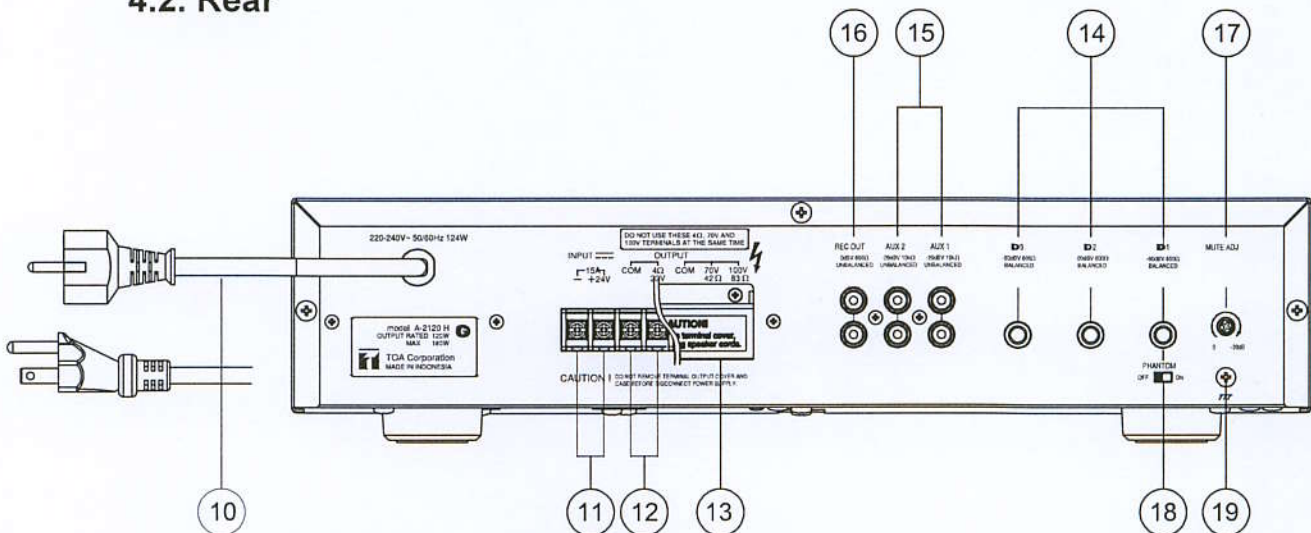

1. **Power Switch**
Press to turn ON the power.
Press again to turn the power STANDBY.
Disconnect the AC mains plug or DC Terminal to shut the power OFF completely.
2. **Power Indicator**
Lights green when power is switched ON.
3. **Signal Indicator**
Lights green when power is switched ON, and indicates an output signal.
4. **Peak Indicator**
Lights red to indicate the output signal reaches the peak level, this indicates that sound is distorted. In such a case, adjust each volume control to reduce output level.
5. **Microphone Volume Control**
Adjusts the microphone level.
6. **AUX Volume Control**
Adjusts the AUX level.
7. **Bass Control**
Adjusts bass response. Rotate clockwise to increase bass output, and counterclockwise to reduce it. The center position provides flat characteristics.
8. **Treble Control**
Adjusts treble response. Rotate clockwise to increase treble output, and counterclockwise to reduce it. The center position provides flat characteristics.
9. **Master Volume Control**
Adjusts the overall signal level.
10. **AC Power Cord**
Connects to an AC power source.
11. **DC Terminal**
Connects to a DC power supply of 24V.
12. **Output Terminals**
Connect to speakers. When connecting speakers use only one of the speaker output terminals, low or high impedance.
13. **Terminal Cover**
To avoid electric shock by high voltage from output terminal, put back the terminal cover after connecting speaker cords.
14. **MIC 1, MIC 2 and MIC 3 Inputs**
 - (Mic 1 : Double Pole Phone Jack)
-60 dB (1mV), 600 Ω, electronically balanced. Not only a dynamic microphone but also phantom powered microphone can connect with only this MIC 1 input.
When it connects Dynamic Microphone, please set phantom switch in OFF by all means.
 - (Mic 2 & Mic 3 : Double Pole Phone Jack)
-60 dB (1mV), 600 Ω, electronically balanced.
Because microphone input is balanced type, phone plug uses double pole type, but can use even Single pole type.
(Refer to Input Connection in detail)
15. **AUX 1 and AUX 2 Input Terminals**
-20dB, 10kΩ, unbalanced. Monaural RCA pin jacks. Accept external equipment output signal.
16. **Recording Output (REC OUT)**
0dB, 600Ω, unbalanced. Outputs all input signals before the master volume control. Connect to a cassette deck, etc when recording the broadcast contents.
17. **Muting Level Control**
Adjusts the background music level 0 ~ 30dB to be automatically reduced when priority function is operated.
18. **Phantom Switch**
Selecting to ON position supplies power for condenser microphones from Mic 1. Be sure to select OFF position when using the microphone that can not be operated on phantom power. This phantom power is 21V DC.
19. **Ground Terminal**
Connect to ground (earth) to avoid electric shock.

5. MUTING FUNCTION

- Mic1 input has a priority function. When Mic1 input is used, it takes precedence and automatically reduces the volume of Mic2, Mic3, Aux1 and Aux2 inputs by 0 to 30 dB, which is adjustable with the MUTE ADJ on rear panel. The attenuation level is preset for -30 dB at the factory.

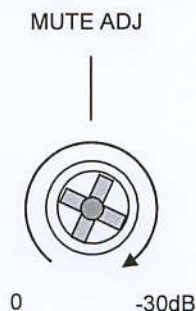

Remark: About Mute function.

- When signal is in Mic1, the mute circuit works promptly.
- When signal Mic1 is disappear, it returns to an old state about 3 seconds later.

6. INSTALLATION

Keep the unit's all sides over 10 cm (3.94 inches) away from object that may obstruct air flow to prevent the unit's internal temperature rise.

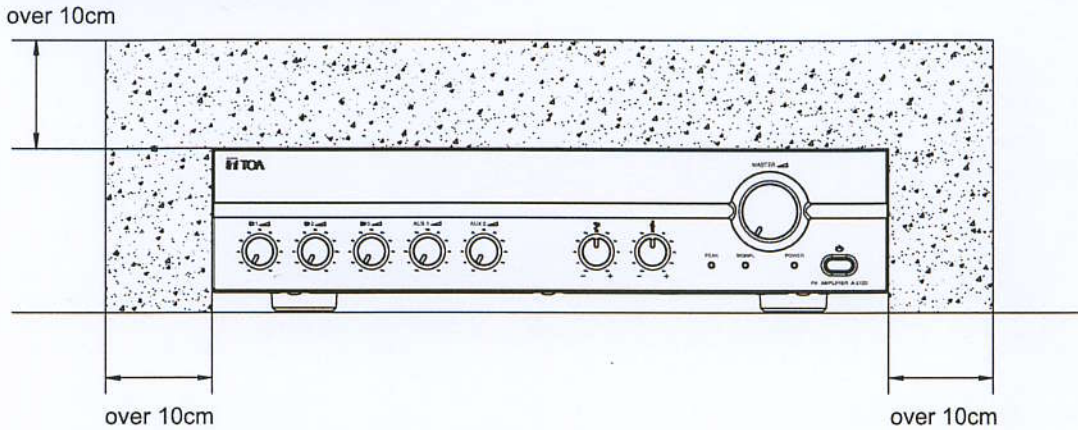

7. CONNECTIONS

7.1. Input Connections

- Mic1, Mic2, Mic3 Connection (Phone Plug)
Because MIC input is electronically balanced type, it uses double pole phone plug.

Double Pole Phone Plug

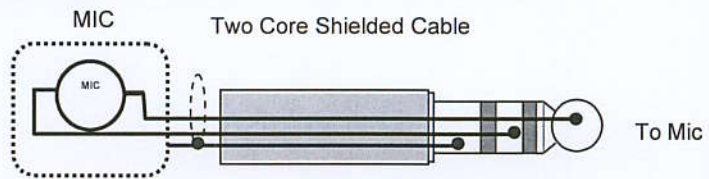

Phantom Switch Position
In the case of Dynamic Microphone



In the case of Phantom Power Microphone



However, the microphone input circuit is in a condition of unbalance when it uses Single pole type. Because it is easy to pick up noise with the state of unbalance, the length of the microphone cable recommends what is used at less than 10m.

Single Pole Phone Plug

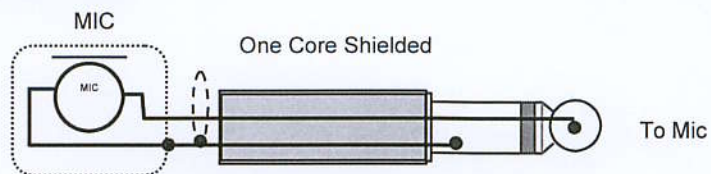
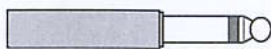

- AUX input Connections (RCA pin jack)

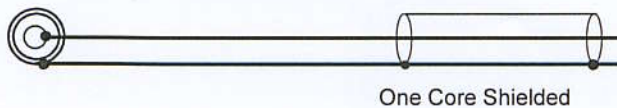

Signal source (Tuner, Cassette Tape, etc)

7.2. Output Connections

- Low Impedance Speaker

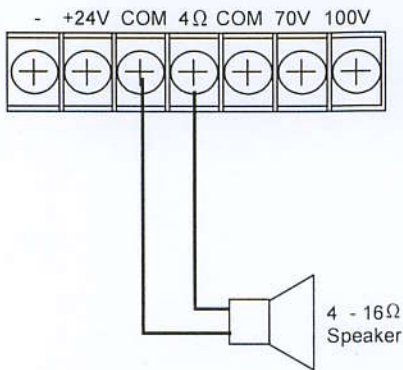

- 70V Line Speaker

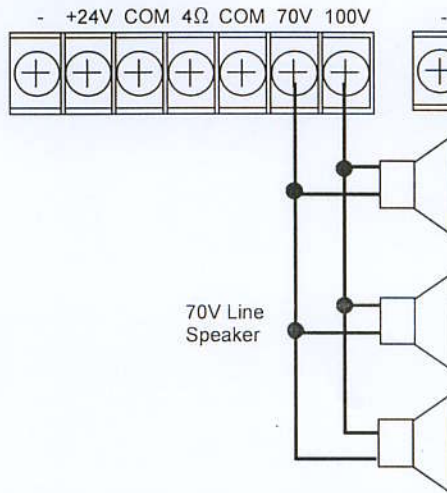

- 100V Line Speaker

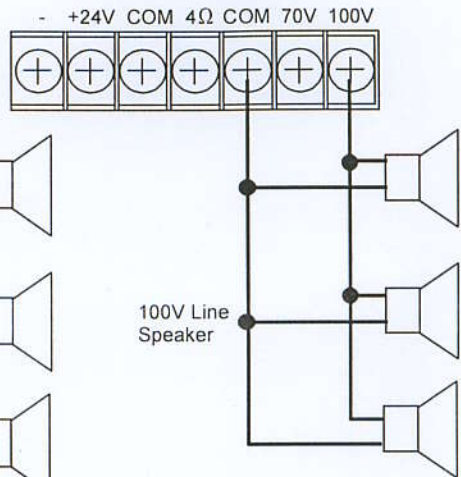

CAUTION!

- Tripartite the 4Ω, 70V and 100V terminals cannot be used at the same time.
- Impedances indicated at the terminal represent the total speaker system (load) impedances.

Total impedances of 100V line:

- 330 Ω (A-2030)
- 170 Ω (A-2060)
- 83 Ω (A-2120)
- 42 Ω (A-2240)

Total impedances of 70V line:

- 170 Ω (A-2030)
- 83 Ω (A-2060)
- 42 Ω (A-2120)
- 21 Ω (A-2240)



CAUTION

Be sure to attach the supplied terminal cover after connection completion. Because high voltage is applied to the speaker terminals, never touch these terminals to avoid electric shock.

7.3. Example of External Equipment Connections

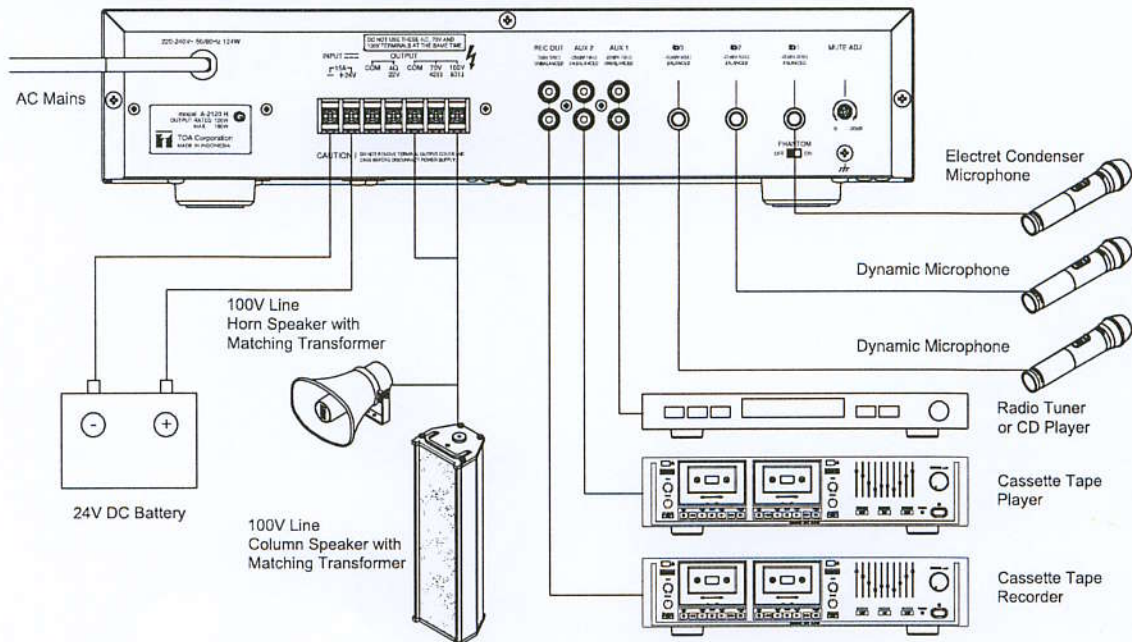

8. VOLUME CONTROL SETTINGS

Output levels are adjustable with individual volume controls. For music play or announcement, adjust the corresponding volume control so that the red peak indicator lights intermittently. Note that the sound quality is downgraded when the peak indicator remains lit.

9. BLOCK & LEVEL DIAGRAM

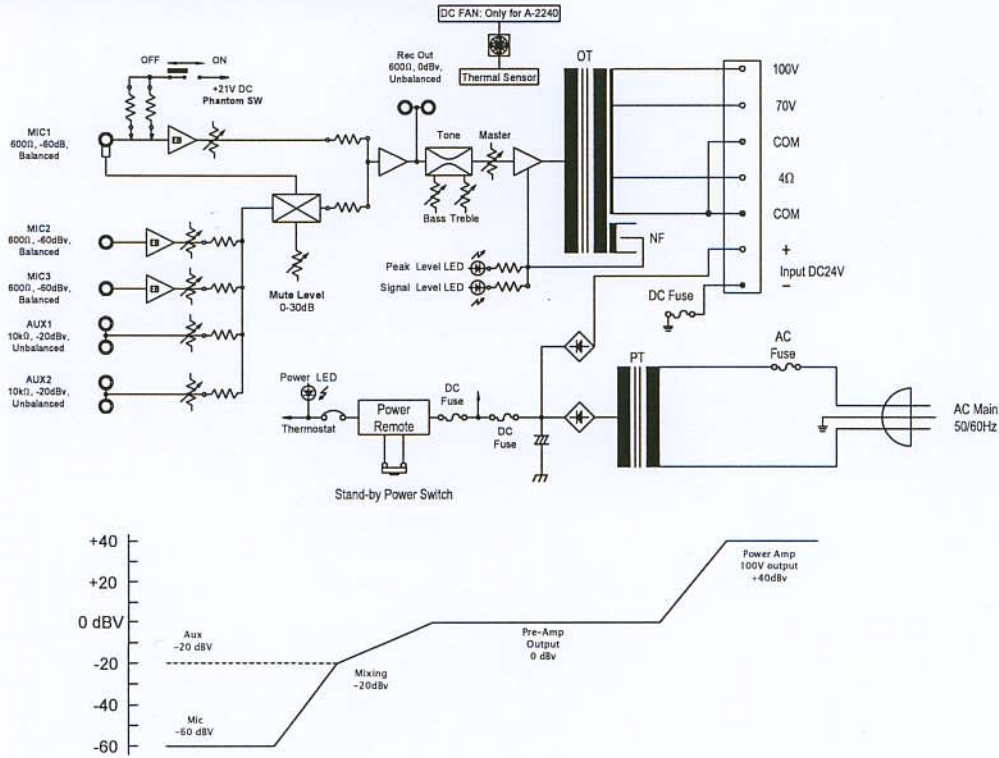

10. DIMENSIONAL DIAGRAM

- A-2030 L, A-2030 H
- A-2060 L, A-2060 H

- A-2120 L, A-2120 H
- A-2240 L, A-2240 H

units: mm(inches)

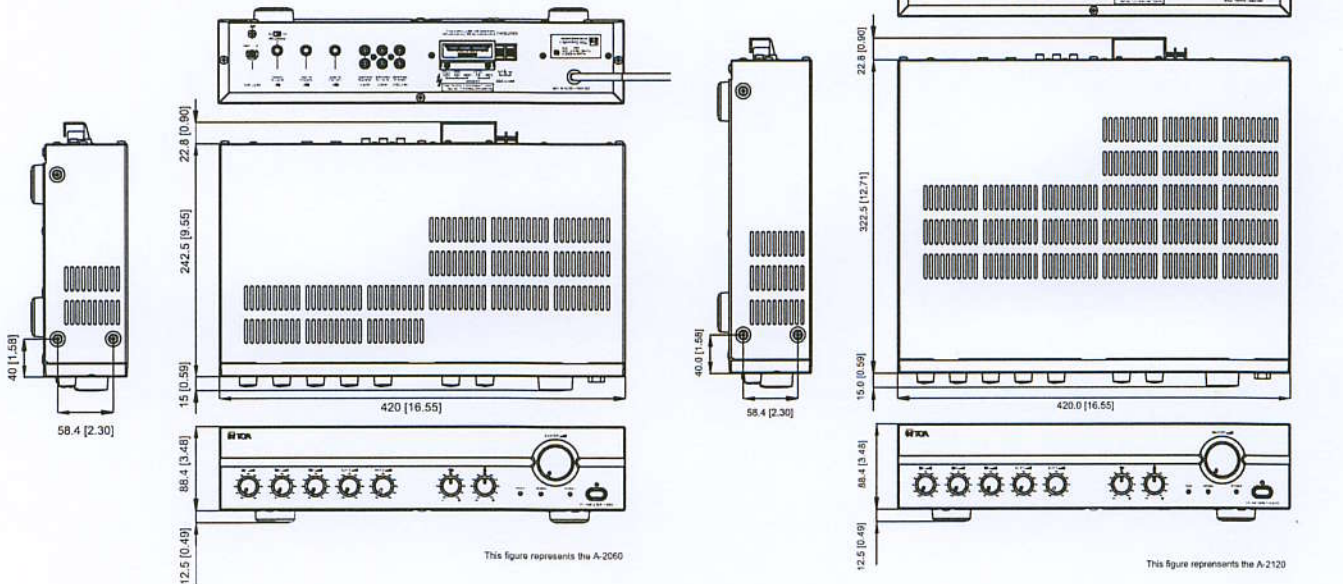

11. SPECIFICATIONS

Model No.	A-2030 L-H	A-2060 L-H	A-2120 L-H	A-2240 L-H
Power Source	H version : 220 - 240V AC or 24V DC L version : 110 - 120 AC or 24V DC			
Rated Output	30 W	60 W	120 W	240 W
Power Consumption (IEC60065)	34 W	72 W	124 W	238 W
DC Current Consumption (at rated output)	2 A	4 A	8 A	15 A
Frequency Response	50 - 20,000 Hz, ± 3 dB			
Distortion	Less Than 1% at 1 kHz, 1/3 Rated Power			
Inputs	MIC 1	-60 dBV (1.0 mV), 600 Ω , Balanced, Equivalent to Phone Jack		
	MIC 2	-60 dBV (1.0 mV), 600 Ω , Balanced, Equivalent to Phone Jack		
	MIC 3	-60 dBV (1.0 mV), 600 Ω , Balanced, Equivalent to Phone Jack		
	AUX 1	-20 dBV (100 mV), 10 k Ω , Unbalanced, RCA Pin Jack		
	AUX 2	-20 dBV (100 mV), 10 k Ω , Unbalanced, RCA Pin Jack		
Outputs	Speaker Out	All Speaker Outputs are Floating Balanced		
	100 V	330 Ω	170 Ω	83 Ω
	70 V	170 Ω	83 Ω	42 Ω
	4 Ω	11 V	15.5 V	22 V
Rec Out	0dBV (1.0V), 600 Ω , Unbalanced, RCA Pin Jack			
Phantom Power	DC +21 V (MIC1)			
S/N Ratio	Over 60 dB			
Tone Controls	Bass: ± 10 dB at 100 Hz Treble: ± 10 dB at 10 kHz			
Muting	MIC1 overrides other input signals with 0 - 30 dB attenuation by voice switch of MIC1 input level.			
Ventilation	-----	-----	-----	Cooling Fan
Indicators	Power LED, Signal LED, Peak LED			
Finish	Panel: ABS Resin, Black Case: Steel Plate, Black			
Dimensions	420(W) x 101(H) x 280(D) mm 16.5(W) x 4.0(H) x 11.0(D) inches		420(W) x 101(H) x 360(D) mm 16.5(W) x 4.0(H) x 14.2(D) inches	
Weight	5.0 kg 11.05 lb	7.0 kg 15.43 lb	10.8 kg 23.81 lb	13.2 kg 29.10 lb
H and L are the identically same specifications, but only power supply cord and AC power source is different.				

*) 0 dBV = 1.0 V

**) Specifications are measured on 240V AC for H version and 120V for L version.

Note: The design and specifications are subject to change without notice for improvement.